

Pro-VCS™ Application Example: WIND SPEED SWITCH

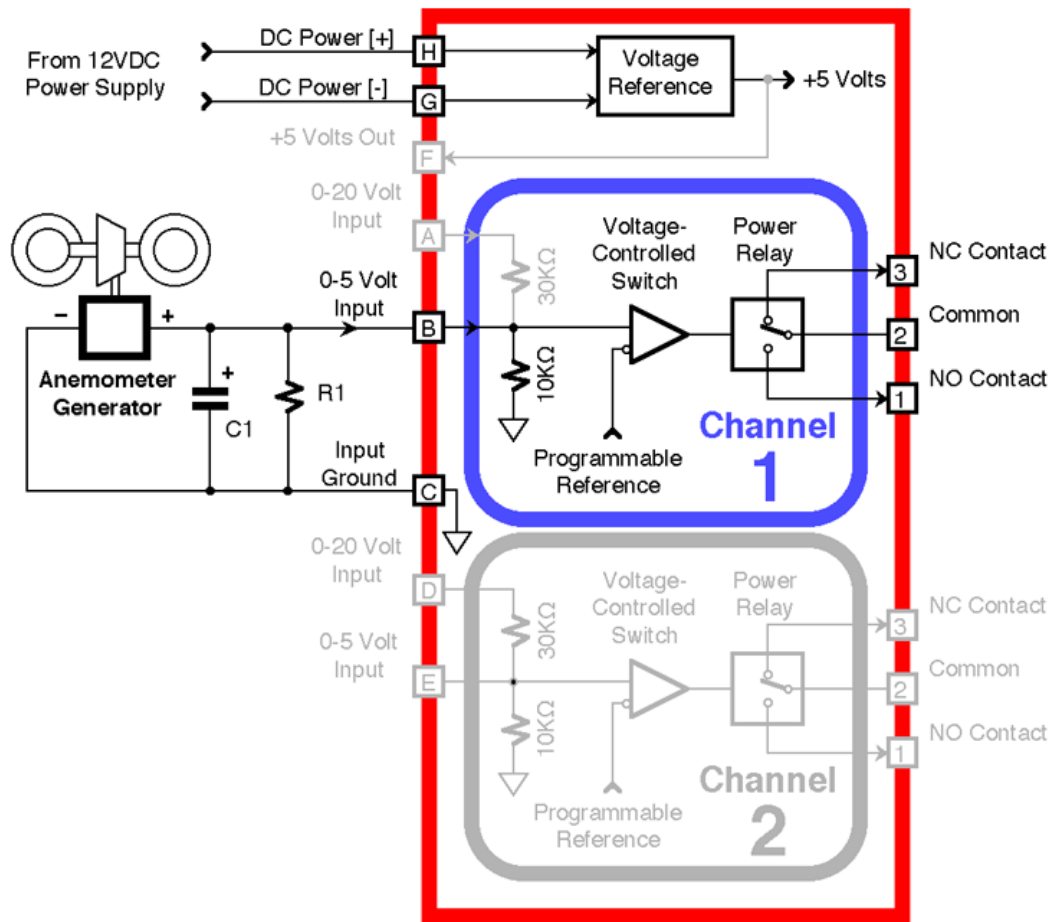

©2012 LSL Products

This configuration uses an anemometer generator that produces a voltage which is proportional to the wind speed - essentially, it's a small DC generator* attached to wind cups or a propeller. The harder the wind blows, the faster the generator spins, resulting in more DC output voltage. Consequently, the **Pro-VCS's** relay will actuate when the wind rises above the **Von** setting programmed into the unit.

A typical application might be to automatically lower a large antenna or retract a power-operated patio awning during dangerously high winds. Only one of **Pro-VCS's** two channels is required to build this circuit.

Capacitor C1 is used to smooth out any DC ripple or brush noise produced by the generator - The optimum value will vary with the particular generator used, but a 220 uF 16 WVDC aluminum electrolytic capacitor is a good starting point. Similarly, resistor R1 is optional, and is chosen to limit the generator's maximum DC output voltage in high winds to less than 5 volts.

*Many small permanent-magnet DC motors will also produce a DC voltage when spun, and are often used as anemometer generators.